



LATE MODEL RULES WDLMA Sanction

The rules and/or regulations set forth herein are designed to provide for the orderly conduct of racing events and to establish minimum acceptable requirements for such events. These rules shall govern the condition of all events, and by participating in these events, all participants are deemed to have complied with these rules. NO EXPRESSED OR IMPLIED WARRANTY OF SAFETY SHALL RESULT FROM PUBLICATION OF OR COMPLIANCE WITH THESE RULES AND/OR REGULATIONS. They are intended as a guide for the conduct of the sport and are in no way a guarantee against injury or death to a participant, spectator, or official.

The race director and or competition director shall be empowered to permit reasonable and appropriate deviation from any of the specifications herein or impose any further restrictions that in his opinion do not alter the minimum acceptable requirements. NO EXPRESSED OR IMPLIED WARRANTY OF SAFETY SHALL RESULT FROM SUCH ALTERATION OF SPECIFICATIONS. Any interpretation or deviation of these rules is left to the discretion of the officials. Their decision is final.

ENGINES

All engines must be approved by series officials.

EWSCA "flat tappet" engines "wet sump" only

362 cubic inch maximum

cast iron block

cast iron head - stock valve angle + or - 1 °

flat tappet camshaft

no titanium or aluminum (rods)

Up to 10" set back **Cars that raced with PDTR or EWSCA in 2005 under EWSCA rule, will be grandfathered.

2200 lbs

12" spoiler

Only grandfathered cars allowed. No new cars built to this spec will be allowed.

WISSOTA "steel or spec aluminum headed" engine

362 cubic inch maximum

cast-iron block

cast iron heads or aluminum spec heads

All heads - no removal of material

Stock valve angle + or - 1 °

Chevy "Bowtie"/ World Products Sportsmen II No. 1115 casting # 1-037

(refer to WISSOTA book for clarification)

Chrysler WZ heads,

Ford SVO heads M-6049-E-351,

M-6049-N-351,

Aluminum heads - Brodix Spec heads

Chevy - SPCH WISSOTA

Ford - SPFO WISSOTA

Mopar - SPMO - WISSOTA

Up to 10 " setback

2300 lbs,

8" spoiler

WISCONSIN DIRT LATE MODEL ASSOCIATION

Spec Engine; Definition, Weight classes

Any engine meeting the following guidelines shall be defined as a "SPEC" engine and shall run @ 2250 lbs . Spoiler blade of 10" shall be allowed.

SPEC engines shall be available for inspection at any time. SPEC engine definition:

Block Steel, Max. bore of 4.060 , 362 CID max

NO BIG BORE SHORT STROKE ENGINES ALLOWED

Crankshaft & Rods No titanium or aluminum allowed ! Any combination allowed that keeps CID@362 or less with a maximum bore size of 4.060. No undercut or scalloped crankshafts allowed. 1" inspection plug required in the oil pan. Plug must be in-line with a crankshaft journal & cannot be obstructed by the windage tray. Plug should be accessible with the engine installed in the racecar.

Heads Brodix 11SPX-SUPR,

Valves No Titanium valves

Intake Brodix HV1000

SUPR Logo's must be un-altered in all cases in both heads & intake.

Pistons & Compression: 10.9:1 Must use Flat Top pistons, Zero Deck.

Single 4 barrel carburetor for all engines

Intake ports may be matched to fel Pro 1206 Gasket refer to Supr rule book for more information

OPEN ENGINE COMBINATIONS and all engines over 362 CID

6" maximum setback

2350 lbs,

8" spoiler 44" total

CRATE

Crate motor cars will run same body rules as other classes.

Crate motor minimum weight is 2150 lbs. 12" spoiler allowed (check side board drawing). Deck 36" - 12" spoiler 48" total. Factory sealed motors only

BODY & CHASSIS

Any UMP, WDRL, WISSOTA or EXTREME legal combination allowed

Rear deck height 36"

WISSOTA & UMP spoiler 8" total 44"

Supr spoiler 10" total 46"

Crate spoiler 12" total 48"

See drawing for board size for Supr & Crate

WHEELBASE

The minimum average wheelbase permitted will be 103 inch (to check turn steering wheel until left side measures 103 - do not touch wheel and check right side - it should measure 103 minimum.

TIRES at weekly shows at Plymouth (PDTR)

D55's all the way around - must be approved by series officials

NO OPEN COMP 55's

Grooving and Siping OK

Check with durometer

WISSOTA D-55

D55 WRS (WDRL tire) & WRS II pre grooved

D55 Hoosier (economy)

All NON-PDTR see extra page for tire rule

Muffler's

Mufflers required: Schoenfeld #112535 (for all Shows)

MISC

DESIGNATE IF CAR IS BURNING ALCOHOL WITH LETTER "A" ON WINDOW POST OR ROOF ON BOTH SIDES

NO ANTIFREEZE

NO SPOTTERS OR RADIOS

NO RUB RAILS ALLOWED

CAR NUMBERS

In addition to number on each side, four inch numbers should displayed on the nose of the car. The weight of the car must be displayed on both sides of the windshield posts.

SPOILER TEMPLATE

Template size for 10" spoiler per drawing:

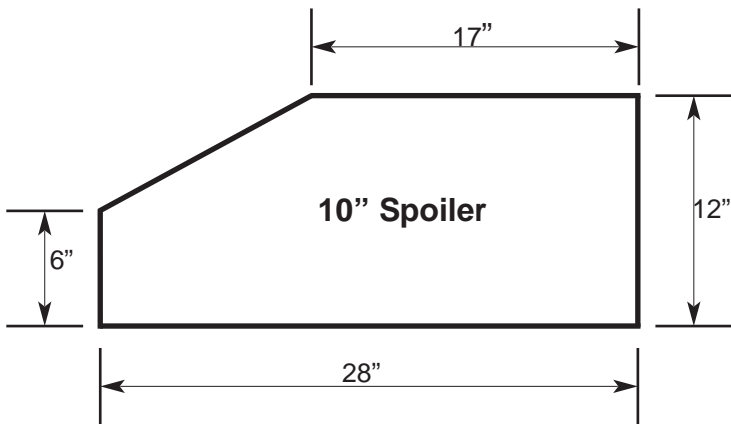

Template size for 12" spoiler per drawing:

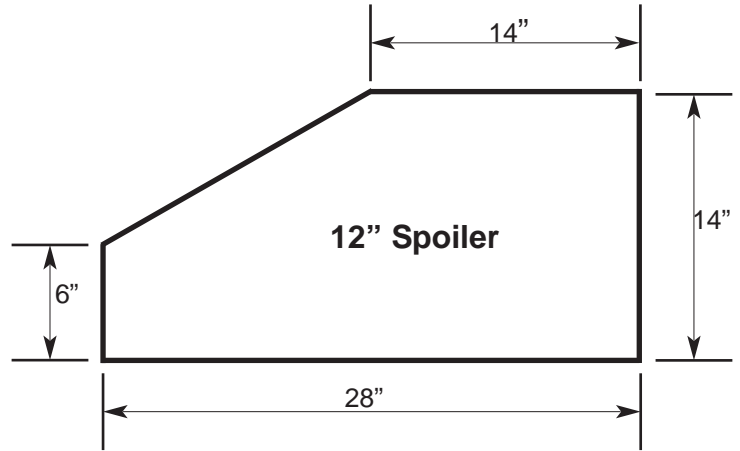

It is my wish and hope that these rules will make for a very competitive racing enviroment. It is my mission to move dirt track racing forward without starting another separate class. We need more cars at the events we have. We do not need a separate and restrictive set of rules and another class to dilute the field.

I try to run the W.D.L.M.A. as fairly as possible. Unlike other sanctioning bodies, we have no sanction, entry or license fees. I take no monies or sanction fees from the promoters. I pay all my own expenses.

Thanks,

Bill Behling

Bill Behling